

Load**LIFTER** 5000™ **ULTIMATE**

ADJUSTABLE AIR HELPER SPRINGS

TOW AND HAUL WITH SAFETY AND COMFORT™



Kit Number
88215

INSTALLATION GUIDE

For maximum effectiveness and safety, please read these instructions completely before proceeding with installation.

Failure to read these instructions can result in an incorrect installation.

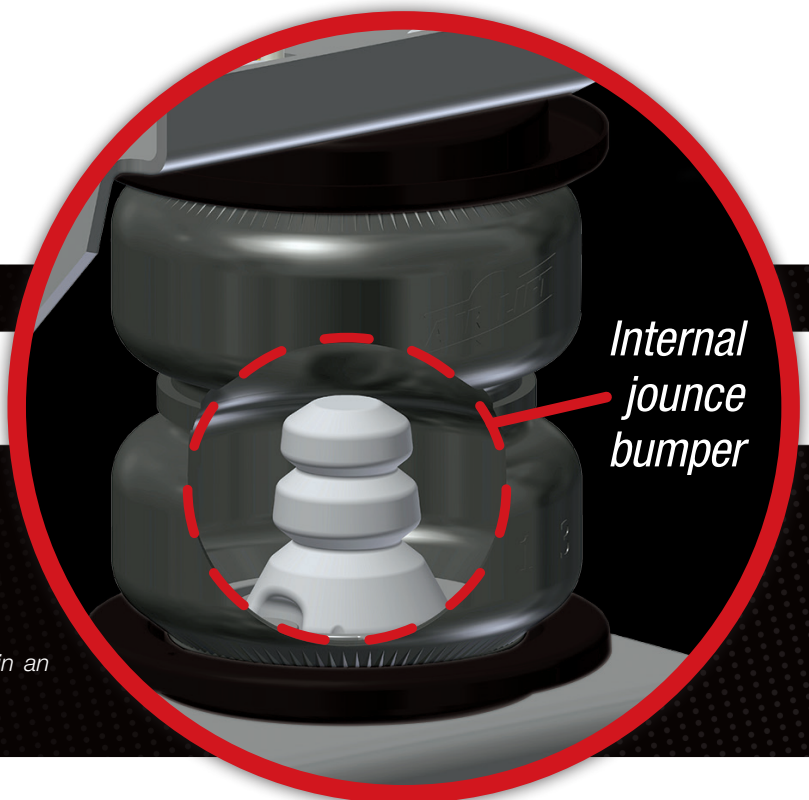

TABLE OF CONTENTS

Introduction	2
Important Safety Notice	2
Notation Explanation	2
Installation Diagram	3
Hardware List	4
Installing the LoadLifter 5000 Ultimate System	4
5th Wheel Hitch	4
Getting Started	4
Special Application Instructions	5
Assembling the Air Spring Unit	6
Positioning the Brackets	7
Attaching the Lower Bracket	7
Attaching the Upper Bracket	8
Securing the Air Spring to the Brackets	9
Installing the Air Lines	9
Reinstalling the Fenderwell Liner (Late Model 4WD Dodge Only)	10
Checking For Leaks	11
Fixing Leaks	11
Before Operating	12
Installation Checklist	12
Post-Installation Checklist	12
Product Use, Maintenance and Servicing	13
Minimum and Maximum Pressure	13
Maintenance Guidelines	13
Troubleshooting Guide	13
Frequently Asked Questions	14
Tuning the Air Pressure	14
Guidelines for Adding Air	15
Choosing the Right On-Board Air Compressor System	16
Warranty and Returns Policy	17
Replacement Information	18
Contact Information	18

Introduction

The purpose of this publication is to assist with the installation, maintenance and troubleshooting of the LoadLifter 5000 Ultimate air spring kit. LoadLifter 5000 Ultimate utilizes sturdy, reinforced, commercial grade single or double, depending on the kit, convolute bellows. The bellows are manufactured like a tire with layers of rubber and cords that control growth. An internal jounce bumper inside the spring absorbs shock and eliminates harsh jarring on rough roads. The internal jounce bumper replaces the factory bumper and allows the air springs to safely be run at zero air pressure. LoadLifter 5000 Ultimate kits are recommended for most $\frac{3}{4}$ and 1 ton pickups and SUVs with leaf springs and provide up to 5,000 lbs. of load leveling support with air adjustability from 5-100 PSI. The kits are also used in motorhome rear kits and some motorhome fronts where leaf springs are used.

It is important to read and understand the entire installation guide before beginning installation or performing any maintenance, service or repair. The information here includes a hardware list, tool list, step-by-step installation information, maintenance tips, safety information and a troubleshooting guide.

Air Lift Company reserves the right to make changes and improvements to its products and publications at any time. For the latest version of this manual, contact Air Lift Company at (800) 248-0892 or visit our website at www.airliftcompany.com.

IMPORTANT SAFETY NOTICE

The installation of this kit does not alter the Gross Vehicle Weight Rating (GVWR) or payload of the vehicle. Check your vehicle's owner's manual and do not exceed the maximum load listed for your vehicle.

Gross Vehicle Weight Rating: The maximum allowable weight of the fully loaded vehicle (including passengers and cargo). This number — along with other weight limits, as well as tire, rim size and inflation pressure data — is shown on the vehicle's Safety Compliance Certification Label.

Payload: The combined, maximum allowable weight of cargo and passengers that the vehicle is designed to carry. Payload is GVWR minus the Base Curb Weight.

NOTATION EXPLANATION

Hazard notations appear in various locations in this publication. Information which is highlighted by one of these notations must be observed to help minimize risk of personal injury or possible improper installation which may render the vehicle unsafe. Notes are used to help emphasize areas of procedural importance and provide helpful suggestions. The following definitions explain the use of these notations as they appear throughout this guide.

 **DANGER**

INDICATES IMMEDIATE HAZARDS WHICH WILL RESULT IN SEVERE PERSONAL INJURY OR DEATH.

 **WARNING**

INDICATES HAZARDS OR UNSAFE PRACTICES WHICH COULD RESULT IN SEVERE PERSONAL INJURY OR DEATH.

 **CAUTION**

INDICATES HAZARDS OR UNSAFE PRACTICES WHICH COULD RESULT IN DAMAGE TO THE MACHINE OR MINOR PERSONAL INJURY.

NOTE

Indicates a procedure, practice or hint which is important to highlight.

Installation Diagram

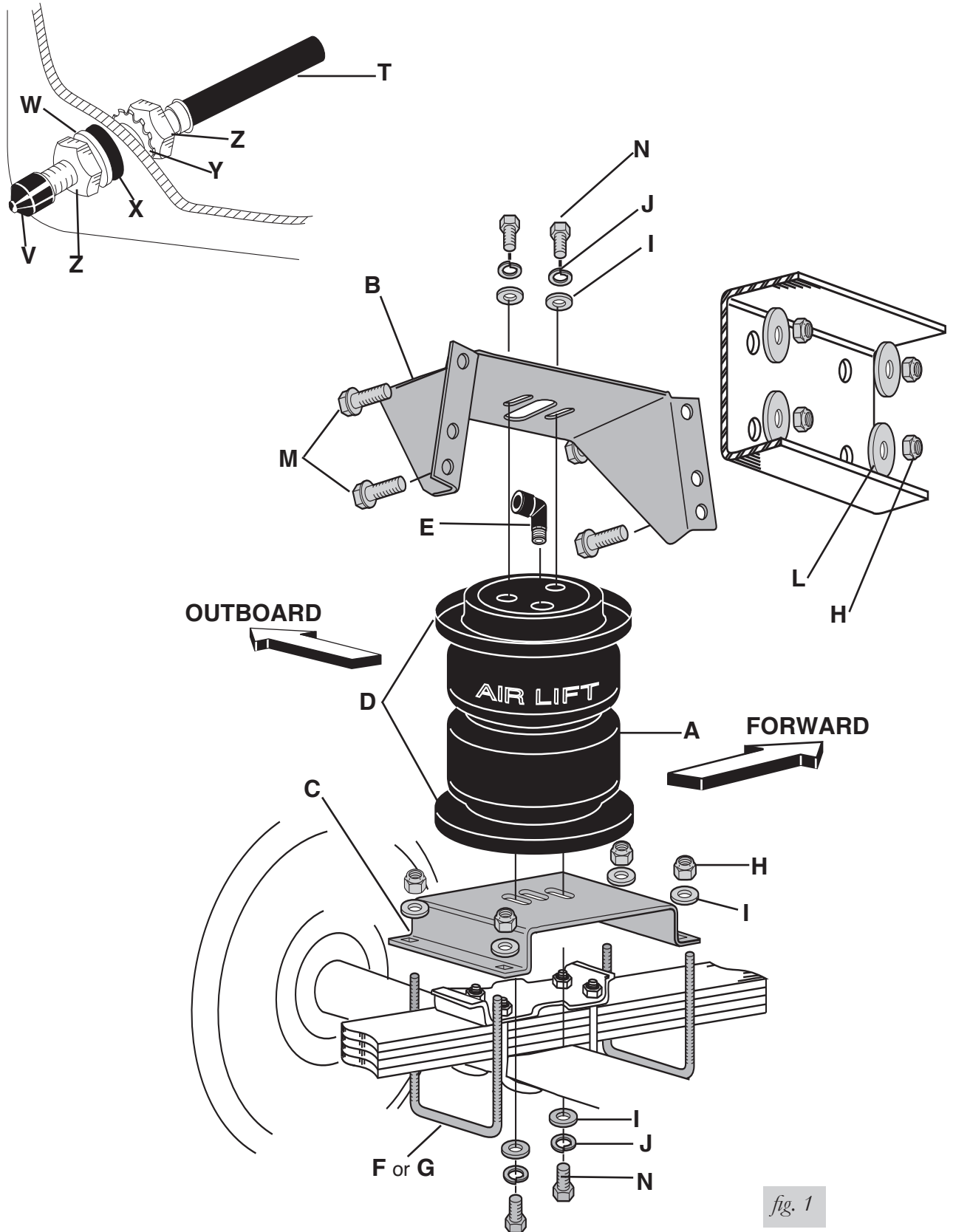

fig. 1

HARDWARE LIST

Item	Part #	Description.....Qty	Dodge Fenderwell Spacer Parts	
A	58437	Bellows.....2	P	17182 1/2" x 2" HHCS*2
B	07475	Upper bracket2	Q	20947 Fenderwell liner spacer*2
C	03102	Lower bracket2	R	18419 10/32" Flat washer*6
D	11967	Roll plate.....4	S	18425 1/4" Nyloc nut*2
E	33606	Elbow fitting.....2	Air Line Assembly	
F	10594	2" U-bolt4	T	20086 Air line assembly*1
G	10583	4.5" U-bolt4	U	10466 Tie strap*6
H	18435	Nyloc nut.....16	V	21230 Valve caps*2
I	18444	3/8" Flat washer16	W	18405 5/16" Flat washer*2
J	18427	3/8" Lock washer.....8	X	21234 Rubber washer*2
K	13377	Upper bracket spacer*8	Y	18411 Small star washer*2
L	18447	3/8" Large flat washer8	X	21233 5/16" Hex nut*4
M	17159	3/8" x 1.5" Washer head frame bolt8		
N	17203	3/8" x 7/8" Hex head cap screw8		
O	01525	Spacer bar*4	*Not shown in fig. 1.	



Missing or damaged parts? Call Air Lift customer service at (800) 248-0892 for a replacement part.

Installing the LoadLifter 5000 Ultimate System



COMPRESSED AIR CAN CAUSE INJURY AND DAMAGE TO THE VEHICLE AND PARTS IF IT IS NOT HANDLED PROPERLY. FOR YOUR SAFETY, DO NOT TRY TO INFLATE THE AIR SPRINGS UNTIL THEY HAVE BEEN PROPERLY SECURED TO THE VEHICLE.

GETTING STARTED

1. Support the axle with jack stands, remove the wheels, and raise or lower to obtain normal ride height (figs. 2 and 3).

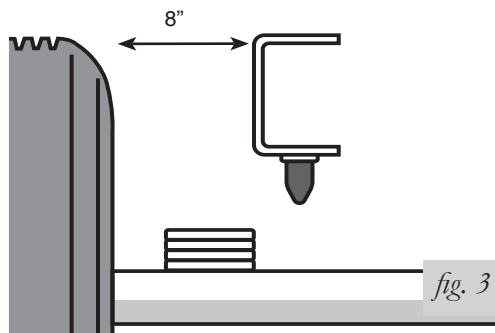
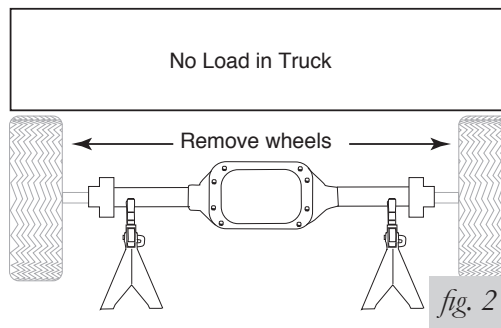

SPECIAL APPLICATION INSTRUCTIONS

1. 1994 model and newer Dodge 4WD pickups only:

It will be necessary to remove the inner fenderwell liner on late model 4WD Dodge trucks. This is done by carefully driving the pin through the fasteners with a center punch (fig. 4). These fasteners will be reused along with a special spacer to reattach the line and provide clearance for the air spring. (See page 10 for reinstallation instructions.)

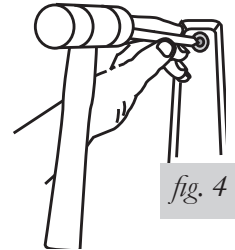

2. Ford trucks only:

When installing the upper bracket on an F-250 or F-350, the mounting bolt holes can line up directly over the indent in the frame. This is an acceptable situation and is an approved method of installation for the product (fig. 5). Torque the mounting hardware to specifications, as noted. Do not over torque.

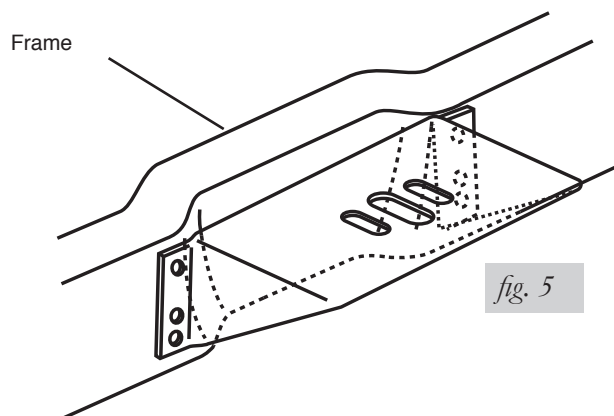

3. For 1999 and later SuperDuty F-250 and F-350 trucks:

Remove the bolt which holds the emergency brake cable to the outside of the frame rail. Reinstall the bolt in the reverse order, with the nut on the inside of the frame rail, to prevent rubbing against the air spring (fig. 6).



FAILURE TO SWITCH THIS BOLT WILL CAUSE AIR SPRING TO RUPTURE.

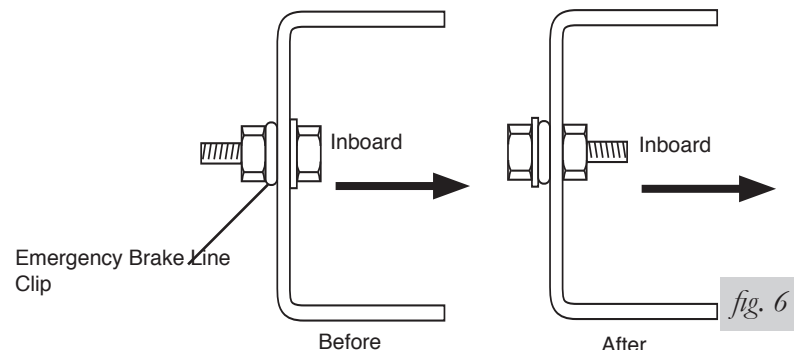

ASSEMBLING THE AIR SPRING UNIT

See fig. 7 below for assembly.

1. Set a roll plate on both ends of the air spring. The radiused (rounded) edge of the roll plate will be towards the air spring so that the air spring is seated in both roll plates.
2. Install a 90° swivel air fitting. It should only be finger tight plus 1½ turns. Do not overtighten.
3. Place the upper bracket onto the top of the air spring and roll plate with the legs facing down.
4. Set the air spring on the lower bracket aligning the two holes in the base of the air spring with the two outer slots in the top of the lower bracket.
5. Loosely attach the upper bracket to the assembly using flat washers, lock washers, and hex head bolts. Remember that the bracket legs face down.
6. Loosely attach the lower bracket to the assembly using flat washers, lock washers, and hex head bolts.

NOTE

The flange on the bracket must face the outside (tire-side) of the vehicle.

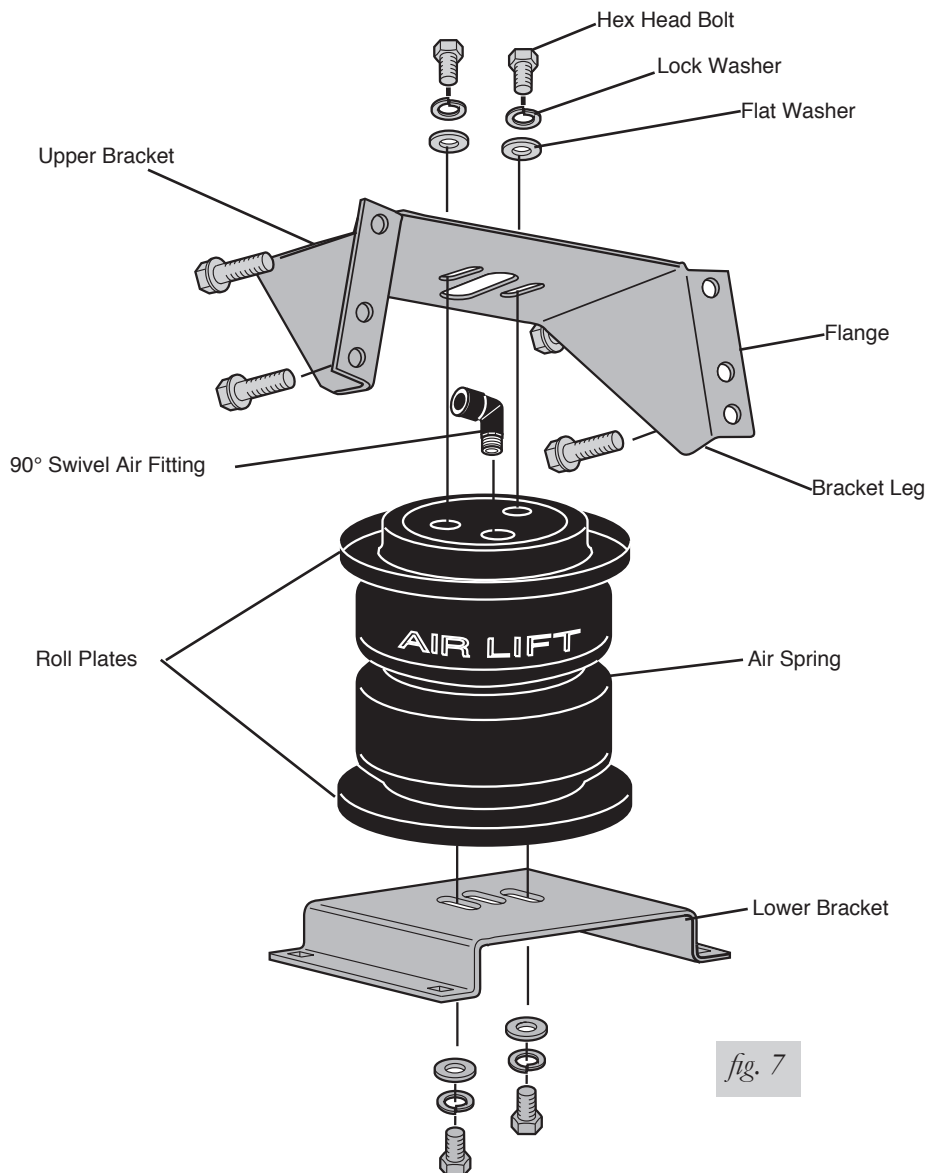

fig. 7

POSITIONING THE BRACKETS

1. The air spring must be installed between 5" and 7" from both the upper bracket to the lower bracket (fig. 8). It is best to position the upper bracket as high as possible.

NOTE

Failure to mount the air spring at the recommended height can result in the air spring bottoming out.

The top rear mounting hole may be above the frame rail. If this condition exists, use the two lower mounting holes to mount the bracket (fig. 8).

2. Set the air spring assembly on the leaf spring over the axle (fig. 8).
3. Position the upper bracket so that at least four bolt holes (two on each side) will be on the flat section of the frame rail. Keep the edge of drilled holes no closer than $\frac{3}{4}$ " from the top or bottom radius of the frame rail.
4. In some cases, it may be necessary to use the optional spacers to achieve the 5"- 7" space (fig. 8). For example, if only the top two holes contact above the lower radius edge of the frame rail, it may be necessary to move up the spacers under the lower bracket to achieve mounting height.

NOTE

If you find that the lower bracket needs to set flat onto the leaf spring in order to achieve the correct height and the stock u-bolts are too high to allow this, it will be necessary to trim the stock u-bolts.

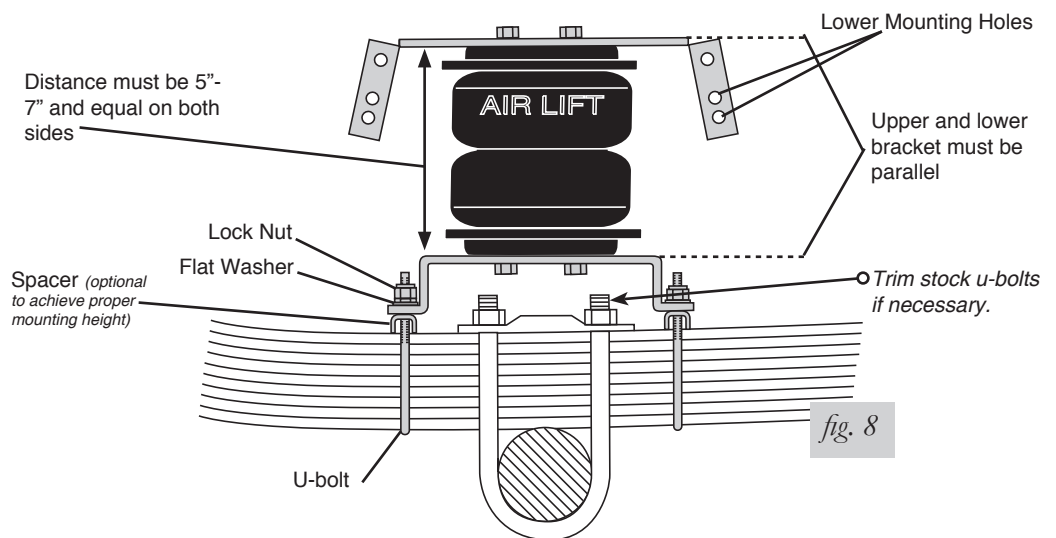

ATTACHING THE LOWER BRACKET

1. If the spacer is not used, attach the lower bracket securely using the provided U-bolts, flat washers, and lock nuts. Torque nuts to 16 ft/lbs. See figures 1 and 9.

NOTE

Use shorter U-Bolts when attaching to frame contact overload springs.

2. If the spacer is used, place the spacers legs down on the leaf spring and attach the lower bracket securely using the provided U-bolts, flat washers, and lock nuts. Torque nuts to 16 ft/lbs (fig. 9).

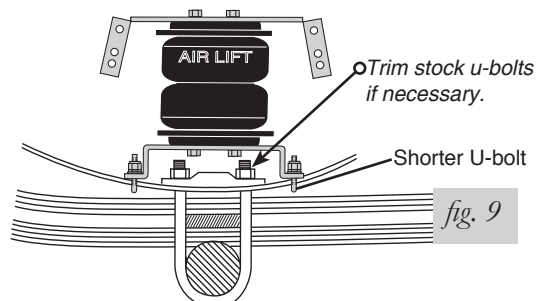

ATTACHING THE UPPER BRACKET

CAUTION

BEFORE DRILLING, CHECK THE BACK-SIDE OF THE FRAME FOR CLEARANCE ISSUES WITH THE BRAKE LINES, GAS LINES, AND ELECTRICAL LINES. ANY OBSTACLES WILL NEED TO BE TEMPORARILY RELOCATED TO CLEAR THE AREA.

1. Position the upper bracket so that it is parallel with the lower bracket and align the assembly vertically and horizontally.
2. Using the upper bracket as a template, center punch and drill one $\frac{3}{8}$ " locator hole through the frame at one of the top bolt holes (fig. 10).

NOTE

After achieving the proper alignment, repeat for the opposite side of the bracket.

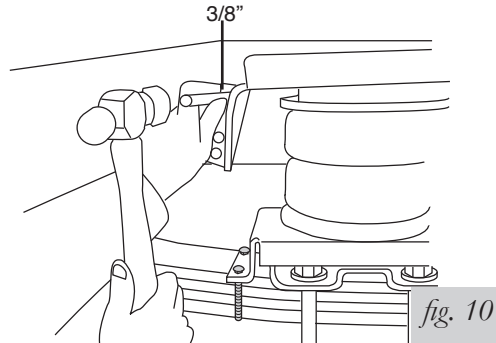

3. Except for Dodge vehicles, loosely install a washer head frame bolt, oversized flat washer, and lock nut (fig. 11).

For Dodge trucks only: The top two, or the bottom two, holes (depending on the model of the truck) will fall into a horizontal indentation. Spacers are provided to compensate for the indentation. Loosely install a washer head frame bolt, two upper bracket spacers, an oversized flat washer, and a lock nut for such instances (fig. 12).

4. Install a washer head frame bolt, oversized flat washer, and lock nut.

For Dodge trucks only: It may be necessary to add two of the provided spacers (fig. 12).

All models, except some late model Dodge trucks

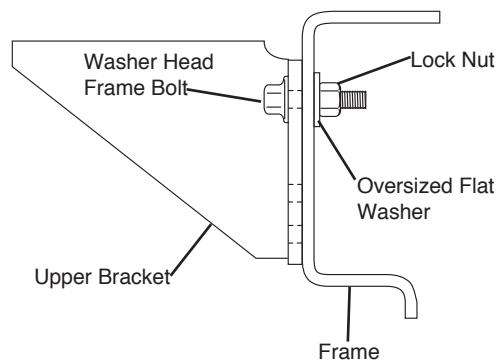

fig. 11

Dodge trucks with ditch (ditch can be on top or bottom portion of the frame, depending on vehicle model)

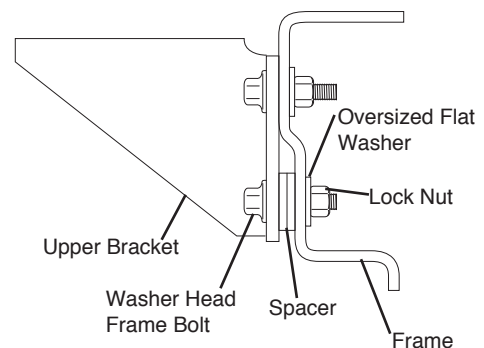
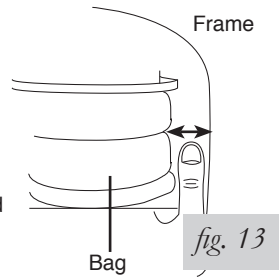

fig. 12

- Remove the clamps and drill the remaining two holes. Install the appropriate hardware and torque the nuts to 44 ft/lbs.
- Align the air spring uniformly between the upper and lower brackets and check the air spring alignment (fig. 13).

Move the air spring in the slots of the upper and lower brackets to align. Make sure there is **at least** a thumbs width of clearance between the uninflated bag and the frame.



SECURING THE AIR SPRING TO THE BRACKETS

- Secure the air spring to the upper and lower brackets using an open ended $\frac{9}{16}$ " wrench by tightening the two bolts on the top and the two bolts on the bottom of the spring assembly.

CAUTION

DUE TO THE THICKNESS OF THE LEAF SPRING STACK, TRIM ALL FOUR U-BOLTS ON EACH SIDE OF THE VEHICLE TO PREVENT BOTTOMING OUT ON THE UPPER BRACKET (FIG. 14).

- Check bolts and connectors to ensure that all hardware is secure and repeat the process for the other side of the vehicle.

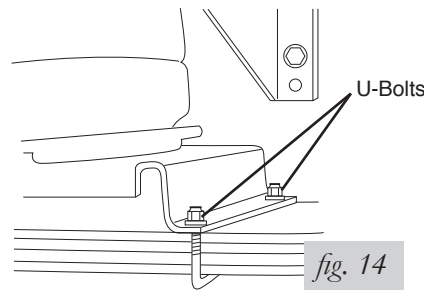

INSTALLING THE AIR LINES

CAUTION

WHEN INSTALLING THE AIR LINES, THERE MUST BE AT LEAST SIX INCHES OF CLEARANCE BETWEEN THE AIR LINES AND ANY HEAT SOURCES.

- Choose a convenient location for mounting the inflation valves. Popular locations for the inflation valves are: The wheel well flanges; The license plate recess in bumper; Under the gas cap access door; or through the license plate (fig. 15).
- Secure air lines with provided tie straps.

NOTE

Whatever the chosen location for the line is, make sure there is enough clearance around the inflation valves for an air chuck.

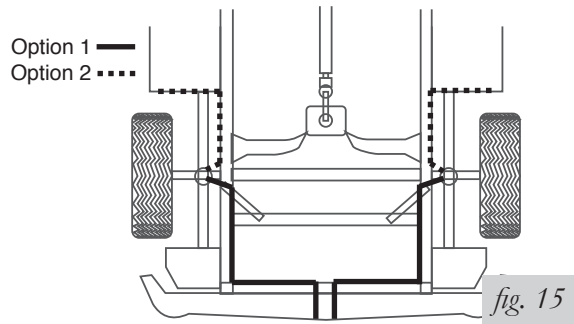

3. Drill a $\frac{5}{16}$ " hole to install the inflation valves.
4. Cut the air line assembly (AA) in two equal lengths.

CAUTION

WHEN CUTTING OR TRIMMING THE AIR LINE, USE A HOSE CUTTER (AIR LIFT P/N 10530), A RAZOR BLADE OR A SHARP KNIFE. A CLEAN, SQUARE CUT WILL ENSURE AGAINST LEAKS. DO NOT USE WIRE CUTTERS OR SCISSORS TO CUT THE AIR LINE. THESE TOOLS MAY FLATTEN OR CRIMP THE AIR LINE CAUSING IT TO LEAK AROUND THE O-RING SEAL INSIDE THE ELBOW FITTING (FIG 16).

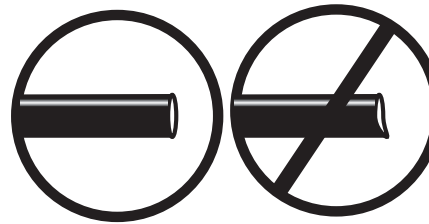

Good Cut

Bad Cut

fig. 16

5. Install the inflation valves as shown in fig. 17.

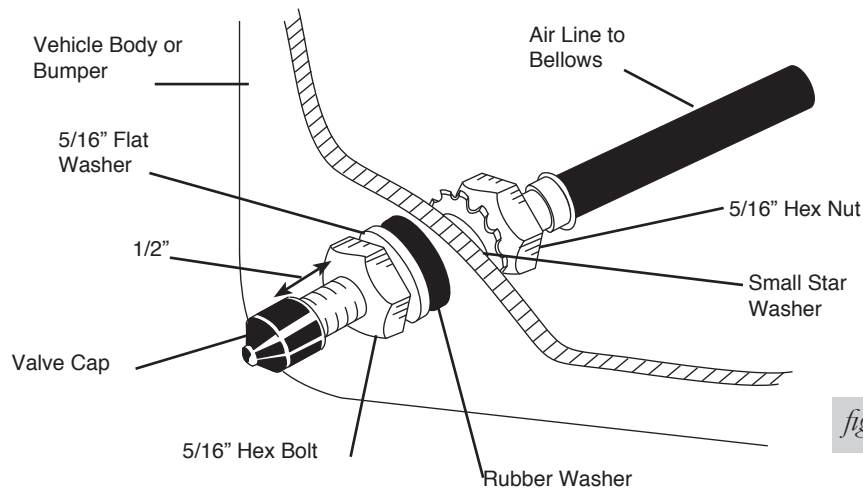

fig. 17

6. Keep at least 6" of clearance between the air line and heat sources, such as the exhaust pipes, muffler, or catalytic converter. Avoid sharp bends and edges. Leave at least 2" of slack when securing the air lines to allow for any movement that might pull on the air line (fig. 18).
7. Cut off air line leaving approximately 12" of extra air line. Insert the air line into the air fitting. Simply push the air line into the 90° swivel fitting until it bottoms out ($\frac{9}{16}$ " of air line should be in the fitting).

REINSTALLING THE FENDERWELL LINER — LATE MODEL 4WD DODGE ONLY

1. If this installation was on a late model 4WD Dodge truck, it is now necessary to reinstall the inner fenderwell liner using the original fasteners and provided spacers to allow for air spring clearance (fig. 18).

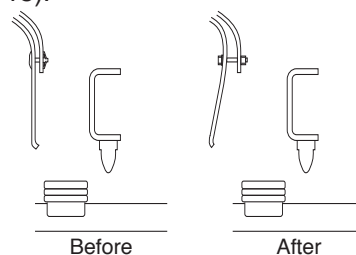

fig. 18

- Place the spacer between the fenderwell liner and the fenderwell at the center hole in the fenderwell liner (the hole nearest the air spring). Attach using the 1/4" Hex Head Cap Screw (HHCS), the 10/32" flat washers, and 1/4" nyloc nut provided (fig. 19).

NOTE

Fasten the HHCS with the washer and nut behind the fenderwell (fig. 19). Tighten securely.

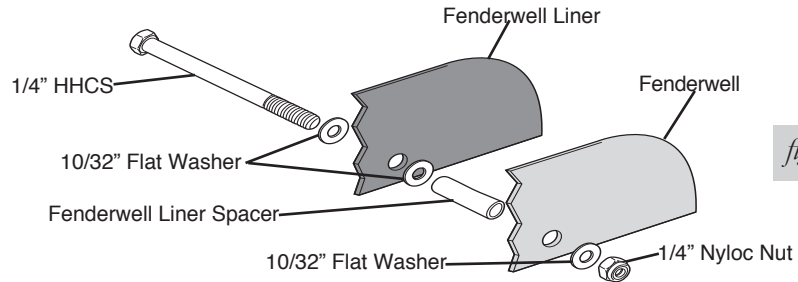
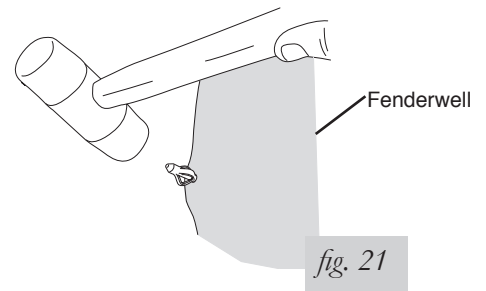
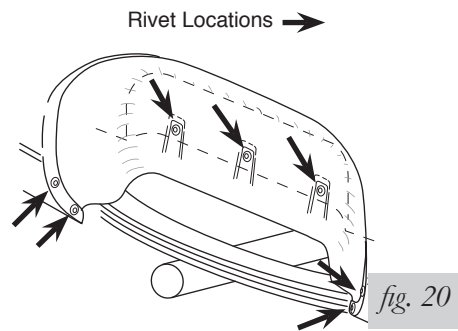

fig. 19

- Replace the remaining fenderwell liner rivets carefully. Push the rivets through the fenderwell liner by hand. They should push through completely (fig. 20).
- From the opposite side, use a rubber mallet and carefully tap the rivet posts back into the rivets in order to secure them properly (fig. 21). Repeat this process for all remaining rivets.



CHECKING FOR LEAKS

- Inflate the air spring to 30 PSI.
- Spray all connections and the inflation valves with a solution of 1/5 liquid dish soap and 4/5 water to check for leaks. You should be able to spot leaks easily by looking for bubbles in the soapy water.
- After the test, deflate the springs to the minimum pressure required to restore the normal ride height, but not less than 10 PSI.
- Check the air pressure again after 24 hours. A 2 - 4 PSI loss after initial installation is normal. Retest for leaks if the loss is more than 5 lbs.

FIXING LEAKS

- If there is a problem with the swivel fitting:
 - Check the air line connection by deflating the spring and removing the line by pulling the collar against the fitting and pulling firmly on the air line. Trim 1" off the end of the air line. Be sure the cut is clean and square (see fig. 12). Reinsert the air line into the push-to-connect fitting.
 - Check the threaded connection by tightening the swivel fitting another 1/2 turn. If it still leaks, deflate the air spring, remove the fitting, and re-coat the threads with thread sealant. Reinstall by hand tightening as much as possible and then use a wrench for an additional two turns.

2. If there is a problem with the inflation valve:
 - a. Check the valve core by tightening it with a valve core tool.
 - b. Check the air line by removing the air line from the barbed type fitting. Cut the air line off a few inches in front of the fitting and use a pair of pliers or vice grips to pull/twist the air line off of the fitting.

CAUTION

DO NOT CUT OFF THE AIR LINE COMPLETELY AS THIS WILL USUALLY NICK THE BARB AND RENDER THE FITTING USELESS.

3. If the preceding steps have not resolved the problem, call Air Lift customer service at (800) 248-0892.

Before Operating

INSTALLATION CHECKLIST (To be completed by installer)

- Clearance test — Inflate the air springs to 60 PSI and ensure there is at least ½” clearance around each bellow, away from anything that might rub against them. Be sure to check the tire, brake drum, frame, shock absorbers and brake cables.
- Leak test before road test — Inflate the air springs to 60 PSI, check all connections for leaks with a soapy water solution. See page 12 for tips on how to spot leaks. All leaks must be eliminated before the vehicle is road tested.
- Heat test — Be sure there is sufficient clearance from any heat sources — at least 6” for air springs and air lines. If a heat shield was included in the kit, install it. If there is no heat shield, but one is required, call (800) 248-0892.
- Fastener test — Recheck all bolts for proper torque. Axle clamp bar carriage bolt lock nuts should be torqued to 16 ft/lbs. Re-torque after 100 miles.
- Road test — The vehicle should be road tested after the preceding tests. Inflate the air springs to 25 PSI (50 PSI if the vehicle is loaded). Drive the vehicle 10 miles and recheck for clearance, loose fasteners and air leaks.
- Operating instructions — If professionally installed, the installer should review the Product Use, Maintenance and Servicing section on page 14 with the owner. Be sure to provide the owner with all of the paperwork which came with the kit.

Technician’s Signature _____

Date _____

POST-INSTALLATION CHECKLIST

- Overnight leak down test — Recheck air pressure after the vehicle has been used for 24 hours. If the pressure has dropped more than 5 PSI, then there is a leak that must be fixed. Either fix the leak yourself or return to the installer for service.
- Air pressure requirements — Regardless of load, the air pressure should always be adjusted to maintain ride height at all times.
- Thirty day or 500 mile test —Recheck the air spring system after 30 days or 500 miles, whichever comes first. If any part shows signs of rubbing or abrasion, the source should be identified and moved, if possible. If it is not possible to relocate the cause of the abrasion, the air spring may need to be remounted. If professionally installed, the installer should be consulted. Check all fasteners for tightness.

Product Use, Maintenance and Servicing

Minimum Recommended Pressure	Maximum Air Pressure
5 PSI	100 PSI

MAINTENANCE GUIDELINES

NOTE

By following the steps below, vehicle owners will obtain the longest life and best results from their air springs.

1. Check the air pressure weekly.
2. Always maintain normal ride height. Never inflate beyond 100 PSI.
3. If you develop an air leak in the system, use a soapy water solution (1/5 liquid dish soap and 4/5 water) to check all air line connections and the inflation valve core before deflating and removing the air spring.

CAUTION

FOR YOUR SAFETY AND TO PREVENT POSSIBLE DAMAGE TO YOUR VEHICLE, DO NOT EXCEED MAXIMUM GROSS VEHICLE WEIGHT RATING (GVWR), AS INDICATED BY THE VEHICLE MANUFACTURER. ALTHOUGH YOUR AIR SPRINGS ARE RATED AT A MAXIMUM INFLATION PRESSURE OF 100 P.S.I., THE AIR PRESSURE ACTUALLY NEEDED IS DEPENDANT ON YOUR LOAD AND GVWR.

4. Loaded vehicles require at least 25 PSI or more. A “loaded vehicle” refers to a vehicle with a heavy bed load, a trailer, or both. As discussed above, never exceed GVWR, regardless of air spring, air pressure, or other load assist. The springs in this kit will support approximately 40 lbs. of load (combined on both springs) for each 1 PSI of pressure. The required air pressure will vary depending on the state of the original suspension. Operating the vehicle below the minimum air spring pressure will void the Air Lift warranty.
5. When increasing load, always adjust the air pressure to maintain the normal ride height. Increase or decrease pressure from the system as necessary to attain normal ride height for optimal ride and handling. Remember that loads carried behind the axle (including tongue loads) require more leveling force (pressure) than those carried directly over the axle.
6. Always add air to springs in small quantities, checking the pressure frequently.
7. Should it become necessary to raise the vehicle by the frame, make sure the system is at minimum pressure (5 PSI) to reduce the tension on the suspension/brake components. Use of on board leveling systems do not require deflation or disconnection.
8. Periodically check the air spring system fasteners for tightness. Also, check the air springs for any signs of rubbing. Realign if necessary.
9. On occasion, give the air springs a hard spray with a garden hose in order to remove mud, sand, gravel or other abrasive debris.

TROUBLESHOOTING GUIDE

1. Leak test the air line connections, the threaded connection into the air spring, and all fittings in the control system.
2. Inspect the air lines to be sure none are pinched. Tie straps may be too tight. Loosen or replace the strap and replace leaking components.
3. Inspect the air line for holes and cracks. Replace as needed.
4. Look for a kink or fold in the air line. Reroute as needed.

If the preceding steps do not solve the problem, it is possibly caused by a failed air spring — either a factory defect or an operating problem. Please call Air Lift at (800) 248-0892 for assistance.

FREQUENTLY ASKED QUESTIONS

Q. Will installing air springs increase the weight ratings of a vehicle?

No. Adding air springs will not change the weight ratings (GAWR, GCWR and/or GVWR) of a vehicle. Exceeding the GVWR is dangerous and voids the Air Lift warranty.

Q. Is it necessary to keep air in the air springs at all times and how much pressure will they need?

For LoadLifter 5000 Ultimate, the recommended minimum air pressure is 5 PSI, but it can safely be run at zero air pressure.

Q. Is it necessary to add a compressor system to the air springs?

No. Air pressure can be adjusted with any type of compressor as long as it can produce sufficient pressure to service the springs. Even a bicycle tire pump can be used, but it's a lot of work.

Q. How long should air springs last?

If the air springs are properly installed and maintained they can last indefinitely.

Q. Will raising the vehicle on a hoist for service work damage the air springs?

No. The vehicle can be lifted on a hoist for short-term service work such as tire rotation or oil changes. However, if the vehicle will be on the hoist for a prolonged period of time, support the axle with jack stands in order to take the tension off of the air springs.

TUNING THE AIR PRESSURE

Pressure determination comes down to three things — level vehicle, ride comfort, and stability.

1. Level vehicle

If the vehicle's headlights are shining into the trees or the vehicle is leaning to one side, then it is not level (fig. 2.1). Raise the air pressure to correct either of these problems and level the vehicle.

2. Ride comfort

If the vehicle has a rough or harsh ride it may be due to either too much pressure or not enough (fig. 2.2). Try different pressures to determine the best ride comfort.

3. Stability

Stability translates into safety and should be the priority, meaning the driver may need to sacrifice a perfectly level and comfortable ride. Stability issues include roll control, bounce, dive during braking and sponginess (fig. 2.3). Tuning out these problems usually requires an increase in pressure.



Bad headlight aim *fig. 2.1*



Rough ride *fig. 2.2*



Sway and body roll *fig. 2.3*

GUIDELINES FOR ADDING AIR

1. Start with the vehicle level or slightly above.
2. When in doubt, always add air.
3. If the front of the vehicle dives while braking, increase the pressure in the front air bags, if equipped.
4. If it is ever suspected that the air bags have bottomed out, increase the pressure (fig. 2.4).
5. Adjust the pressure up and down to find the best ride.
6. If the vehicle rocks and rolls, adjust the air pressure to reduce movement.
7. It may be necessary to maintain different pressures on each side of the vehicle. Loads such as water, fuel, and appliances will cause the vehicle to be heavier on one side (fig. 2.5). As much as a 50 PSI difference is not uncommon.



Bottoming out

fig. 2.4

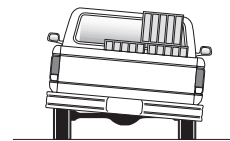

Unlevel

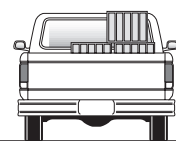

Level

fig. 2.5

Choosing the Right On-Board Air Compressor System

60 DAY NO QUESTIONS ASKED, MONEY-BACK GUARANTEE

TWO YEAR COMPRESSOR SYSTEM WARRANTY

Add an on-board air compressor system to inflate and deflate your air springs with the touch of a button — from inside or outside of the vehicle.

- For convenient, on-the-go control of your air springs, add an Air Lift on-board air compressor system.
- Air Lift on-board air compressor systems eliminate the search for gas stations that have a working compressor, saving you time, energy and money.
- All systems include a compressor, controller and all parts needed for easy installation.

1. Choose single or dual path inflation (see illustrations at right)

2. Choose wireless or analog control

- **Wireless:** Control your air springs from inside or outside the vehicle. Easiest installation - no wires to the cab.
- **Analog:** In-cab control of your air springs. Economically priced.

3. Choose heavy or standard duty compressor

- **Standard duty:** A standard duty compressor will work well for most customers who use their system on an intermittent basis.
- **Heavy duty:** For daily use, consider the heavy duty compressor - it inflates faster and more quietly than the standard compressor.

Visit www.airliftcompany.com for more detailed info on compressor systems.

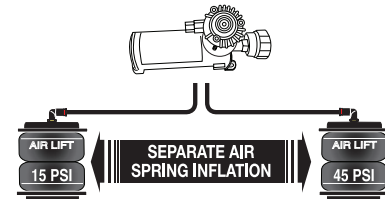

Dual path systems Air springs are controlled separately to allow for different air pressure from side-to-side. Perfect for uneven or top-heavy loads.

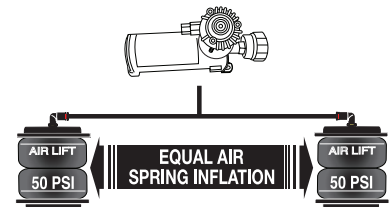

Single path systems Two springs will inflate at the same time. Good for loads that are evenly distributed from left-to-right or front-to-back.

W I R E L E S S

A N A L O G

DUAL PATH

WirelessAIR™

OUR PREMIUM SYSTEM!

- Easy installation
- Includes heavy duty compressor



P/N 72000

SINGLE PATH

WirelessONE™

- Easy installation
- Includes standard duty compressor



P/N 25870

LoadCONTROLLER™

Dual

Compact, economically priced control.



P/N Standard Duty Compressor 25850; P/N Heavy Duty Compressor 25854

LoadCONTROLLER™

Single

Compact, economically priced control.



P/N Standard Duty Compressor 25852; P/N Heavy Duty Compressor 25856



Warranty and Returns Policy

Air Lift Company warrants its products, for the time periods listed below, to the original retail purchaser against manufacturing defects when used on catalog-listed applications on cars, vans, light trucks and motorhomes under normal operating conditions for as long as Air Lift manufactures the product. The warranty does not apply to products that have been improperly applied, improperly installed, used in racing or off-road applications, used for commercial purposes, or which have not been maintained in accordance with installation instructions furnished with all products. The consumer will be responsible for removing (labor charges) the defective product from the vehicle and returning it, transportation costs prepaid, to the dealer from which it was purchased or to Air Lift Company for verification.

Air Lift will repair or replace, at its option, defective products or components. A minimum \$10.00 shipping and handling charge will apply to all warranty claims. Before returning any defective product, you must call Air Lift at (800) 248-0892 in the U.S. and Canada (elsewhere, (517) 322-2144) for a Returned Materials Authorization (RMA) number. Returns to Air Lift can be sent to: Air Lift Company • 2727 Snow Road • Lansing, MI • 48917.

Product failures resulting from abnormal use or misuse are excluded from this warranty. The loss of use of the product, loss of time, inconvenience, commercial loss or consequential damages is not covered. The consumer is responsible for installation/reinstallation (labor charges) of the product. Air Lift Company reserves the right to change the design of any product without assuming any obligation to modify any product previously manufactured.

This warranty gives you specific legal rights and you may also have other rights that vary from state-to-state. Some states do not allow limitations on how long an implied warranty lasts or allow the exclusion or limitation of incidental or consequential damages. The above limitation or exclusion may not apply to you. There are no warranties, expressed or implied including any implied warranties of merchantability and fitness, which extend beyond this warranty period. There are no warranties that extend beyond the description on the face hereof. Seller disclaims the implied warranty of merchantability. (Dated proof of purchase required.)

Air Lift 1000	Lifetime Limited	LoadController/Dual	2 Year Limited
RideControl	Lifetime Limited	Load Controller (I)	2 Year Limited
LoadLifter 5000*	Lifetime Limited	Load Controller (II)	2 Year Limited
LoadLifter 5000 Ultimate ...	Lifetime Limited	SmartAir	2 Year Limited
SlamAir	Lifetime Limited	Wireless AIR	2 Year Limited
AirCell	Lifetime Limited	WirelessONE	2 Year Limited
Air Lift Performance**	1 Year Limited	Other Accessories	2 Year Limited
LoadController/Single	2 Year Limited		

**formerly SuperDuty*
***formerly LifeSTYLE & Performance*

Replacement Information

If you need replacement parts, contact the local dealer or call Air Lift customer service at (800) 248-0892. Most parts are immediately available and can be shipped the same day.

Contact Air Lift Company customer service at (800) 248-0892, first if:

- Parts are missing from the kit.
- Need technical assistance on installation or operation.
- Broken or defective parts in the kit.
- Wrong parts in the kit.
- Have a warranty claim or question.

Contact the retailer where the kit was purchased:

- If it is necessary to return or exchange the kit for any reason.
- If there is a problem with shipping if shipped from the retailer.
- If there is a problem with the price.

Contact Information

If you have any questions, comments or need technical assistance, contact our customer service department by calling (800) 248-0892, Monday through Friday. For calls from outside the USA or Canada, our local number is (517) 322-2144.

For inquiries by mail, our address is PO Box 80167, Lansing, MI 48908-0167. Our shipping address for returns is 2727 Snow Road, Lansing, MI 48917.

You may also contact us anytime by e-mail at sales@airliftcompany.com or on the web at www.airliftcompany.com.

Need Help?

Contact our customer service department by calling (800) 248-0892, Monday through Friday. For calls from outside the USA or Canada, our local number is (517) 322-2144.

**Register your warranty online at
www.airliftcompany.com/warranty**



Thank you for purchasing Air Lift products — the professional installer's choice!

Air Lift Company • 2727 Snow Road • Lansing, MI 48917 or PO Box 80167 • Lansing, MI 48908-0167
Toll Free (800) 248-0892 • Local (517) 322-2144 • Fax (517) 322-0240 • www.airliftcompany.com

Printed in
the USA